

FEATURES

High accuracy

- 0.02% maximum nonlinearity, 0 V to 2 V rms input
- 0.10% additional error to crest factor of 3

Wide bandwidth

- 8 MHz at 2 V rms input
- 600 kHz at 100 mV rms

Computes

- True rms
- Square
- Mean square
- Absolute value

dB output (60 dB range)

Chip select/power-down feature allows

- Analog three-state operation
- Quiescent current reduction from 2.2 mA to 350 μ A

14-lead SBDIP, 14-lead low cost CERDIP, and 16-lead SOIC_W

GENERAL DESCRIPTION

The AD637 is a complete, high accuracy, monolithic rms-to-dc converter that computes the true rms value of any complex waveform. It offers performance that is unprecedented in integrated circuit rms-to-dc converters and comparable to discrete and modular techniques in accuracy, bandwidth, and dynamic range. A crest factor compensation scheme in the AD637 permits measurements of signals with crest factors of up to 10 with less than 1% additional error. The wide bandwidth of the AD637 permits the measurement of signals up to 600 kHz with inputs of 200 mV rms and up to 8 MHz when the input levels are above 1 V rms.

As with previous monolithic rms converters from Analog Devices, Inc., the AD637 has an auxiliary dB output available to users. The logarithm of the rms output signal is brought out to a separate pin, allowing direct dB measurement with a useful range of 60 dB. An externally programmed reference current allows the user to select the 0 dB reference voltage to correspond to any level between 0.1 V and 2.0 V rms.

A chip select connection on the AD637 permits the user to decrease the supply current from 2.2 mA to 350 μ A during periods when the rms function is not in use. This feature facilitates the addition of precision rms measurement to remote or handheld applications where minimum power consumption is critical. In addition, when the AD637 is powered down, the output goes to a high impedance state. This allows several AD637s to be tied together to form a wideband true rms multiplexer.

Rev. J

Information furnished by Analog Devices is believed to be accurate and reliable. However, no responsibility is assumed by Analog Devices for its use, nor for any infringements of patents or other rights of third parties that may result from its use. Specifications subject to change without notice. No license is granted by implication or otherwise under any patent or patent rights of Analog Devices. Trademarks and registered trademarks are the property of their respective owners.

FUNCTIONAL BLOCK DIAGRAM

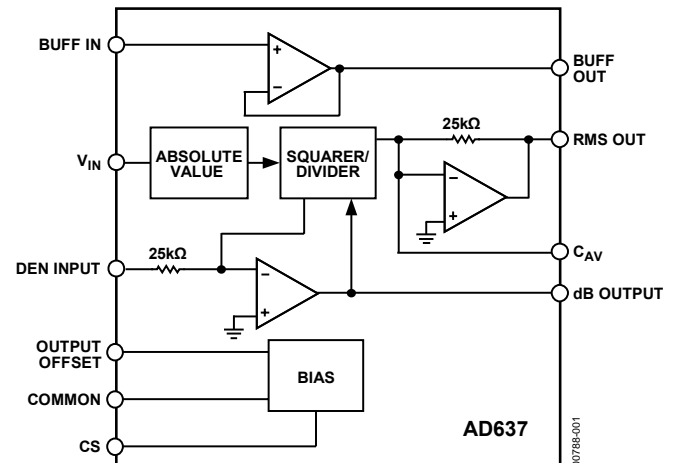

Figure 1.

The input circuitry of the AD637 is protected from overload voltages in excess of the supply levels. The inputs are not damaged by input signals if the supply voltages are lost.

The AD637 is available in accuracy Grade J and Grade K for commercial temperature range (0°C to 70°C) applications, accuracy Grade A and Grade B for industrial range (-40°C to +85°C) applications, and accuracy Grade S rated over the -55°C to +125°C temperature range. All versions are available in hermetically sealed, 14-lead SBDIP, 14-lead CERDIP, and 16-lead SOIC_W packages.

The AD637 computes the true root mean square, mean square, or absolute value of any complex ac (or ac plus dc) input waveform and gives an equivalent dc output voltage. The true rms value of a waveform is more useful than an average rectified signal because it relates directly to the power of the signal. The rms value of a statistical signal is also related to the standard deviation of the signal.

The AD637 is laser wafer trimmed to achieve rated performance without external trimming. The only external component required is a capacitor that sets the averaging time period. The value of this capacitor also determines low frequency accuracy, ripple level, and settling time.

The on-chip buffer amplifier can be used either as an input buffer or in an active filter configuration. The filter can be used to reduce the amount of ac ripple, thereby increasing accuracy.

TABLE OF CONTENTS

Features	1	Choosing the Averaging Time Constant.....	9
Functional Block Diagram	1	Frequency Response	11
General Description	1	AC Measurement Accuracy and Crest Factor	12
Revision History	2	Connection for dB Output.....	12
Specifications.....	3	dB Calibration.....	13
Absolute Maximum Ratings.....	5	Low Frequency Measurements.....	14
ESD Caution.....	5	Vector Summation	14
Pin Configurations and Function Descriptions	6	Evaluation Board	16
Functional Description	7	Outline Dimensions	19
Standard Connection	8	Ordering Guide	20
Chip Select.....	8		
Optional Trims for High Accuracy	8		

REVISION HISTORY

4/07—Rev. I to Rev. J

Added Evaluation Board Section	16
Updated Outline Dimensions	20

10/06—Rev. H to Rev. I

Changes to Table 1.....	3
Changes to Figure 4.....	7
Changes to Figure 7.....	9
Changes to Figure 16, Figure 18, and Figure 19	12
Changes to Figure 20.....	13

12/05—Rev. G to Rev. H

Updated Format.....	Universal
Changes to Figure 1.....	1
Changes to Figure 11.....	10
Updated Outline Dimensions	16
Changes to Ordering Guide	17

4/05—Rev. F to Rev. G

Updated Format.....	Universal
Changes to Figure 1.....	1
Changes to General Description	1
Deleted Product Highlights	1
Moved Figure 4 to Page	8
Changes to Figure 5.....	9
Changes to Figure 8.....	10
Changes to Figure 11, Figure 12, Figure 13, and Figure 14.....	11
Changes to Figure 19.....	14
Changes to Figure 20.....	14
Changes to Figure 21.....	16
Updated Outline Dimensions	17
Changes to Ordering Guide	18

3/02—Rev. E to Rev. F

Edits to Ordering Guide	3
-------------------------------	---

SPECIFICATIONS

At 25°C and ±15 V dc, unless otherwise noted.¹

Table 1.

Parameter	AD637J/AD637A			AD637K/AD637B			AD637S			Unit
	Min	Typ	Max	Min	Typ	Max	Min	Typ	Max	
TRANSFER FUNCTION	$V_{OUT} = \sqrt{\text{avg} \times (V_{IN})^2}$			$V_{OUT} = \sqrt{\text{avg} \times (V_{IN})^2}$			$V_{OUT} = \sqrt{\text{avg} \times (V_{IN})^2}$			
CONVERSION ACCURACY										
Total Error, Internal Trim ² (Figure 5)			±1 ± 0.5			±0.5 ± 0.2			±1 ± 0.5	mV ± % of reading
T _{MIN} to T _{MAX}			±3.0 ± 0.6			±2.0 ± 0.3			±6 ± 0.7	mV ± % of reading
vs. Supply +V _{IN} = 300 mV	30		150	30		150	30		150	μV/V
vs. Supply -V _{IN} = -300 mV	100		300	100		300	100		300	μV/V
DC Reversal Error at 2 V			0.25			0.1			0.25	% of reading
Nonlinearity 2 V Full Scale ³			0.04			0.02			0.04	% of FSR
Nonlinearity 7 V Full Scale			0.05			0.05			0.05	% of FSR
Total Error, External Trim	±0.5 ± 0.1			±0.25 ± 0.05			±0.5 ± 0.1			mV ± % of reading
ERROR VS. CREST FACTOR ⁴										
Crest Factor 1 to 2	Specified accuracy			Specified accuracy			Specified accuracy			% of reading
Crest Factor = 3	±0.1			±0.1			±0.1			
Crest Factor = 10	±1.0			±1.0			±1.0			
AVERAGING TIME CONSTANT	25			25			25			ms/μF C _{AV}
INPUT CHARACTERISTICS										
Signal Range, ±15 V Supply										
Continuous RMS Level	0 to 7			0 to 7			0 to 7			V rms
Peak Transient Input			±15			±15			±15	V p-p
Signal Range, ±5 V Supply										
Continuous RMS Level	0 to 4			0 to 4			0 to 4			V rms
Peak Transient Input			±6			±6			±6	V p-p
Maximum Continuous Nondestructive Input Level (All Supply Voltages)			±15			±15			±15	V p-p
Input Resistance	6.4	8	9.6	6.4	8	9.6	6.4	8	9.6	kΩ
Input Offset Voltage			±0.5			±0.2			±0.5	mV
FREQUENCY RESPONSE ⁵										
Bandwidth for 1% Additional Error (0.09 dB)										
V _{IN} = 20 mV	11			11			11			kHz
V _{IN} = 200 mV	66			66			66			kHz
V _{IN} = 2 V	200			200			200			kHz
±3 dB Bandwidth										
V _{IN} = 20 mV	150			150			150			kHz
V _{IN} = 200 mV	1			1			1			MHz
V _{IN} = 2 V	8			8			8			MHz

AD637

Parameter	AD637J/AD637A			AD637K/AD637B			AD637S			Unit
	Min	Typ	Max	Min	Typ	Max	Min	Typ	Max	
OUTPUT CHARACTERISTICS										
Offset Voltage			±1			±0.5			±1	mV
vs. Temperature		±0.05	±0.089		±0.04	±0.056		±0.04	±0.07	mV/°C
Voltage Swing, ±15 V Supply, 2 kΩ Load	0 to 12.0	13.5		0 to 12.0	13.5		0 to 12.0	13.5		V
Voltage Swing, ±3 V Supply, 2 kΩ Load	0 to 2	2.2		0 to 2	2.2		0 to 2	2.2		V
Output Current	6			6			6			mA
Short-Circuit Current		20			20			20		mA
Resistance Chip Select High		0.5			0.5			0.5		Ω
Resistance Chip Select Low		100			100			100		kΩ
dB OUTPUT										
Error, V_{IN} 7 mV to 7 V rms, 0 dB = 1 V rms		±0.5			±0.3			±0.5		dB
Scale Factor		-3			-3			-3		mV/dB
Scale Factor Temperature Coefficient		+0.33			+0.33			+0.33		% of reading/°C
		-0.033			-0.033			-0.033		dB/°C
I_{REF} for 0 dB = 1 V rms	5	20	80	5	20	80	5	20	80	μA
I_{REF} Range	1		100	1		100	1		100	μA
BUFFER AMPLIFIER										
Input Output Voltage Range	- V_S to (+ V_S - 2.5 V)			- V_S to (+ V_S - 2.5 V)			- V_S to (+ V_S - 2.5 V)			V
Input Offset Voltage		±0.8	±2		±0.5	±1		±0.8	±2	mV
Input Current		±2	±10		±2	±5		±2	±10	nA
Input Resistance		10 ⁸			10 ⁸			10 ⁸		Ω
Output Current	-0.13		+5	-0.13		+5	-0.13		+5	mA
Short-Circuit Current		20			20			20		mA
Small Signal Bandwidth		1			1			1		MHz
Slew Rate ⁶		5			5			5		V/μs
DENOMINATOR INPUT										
Input Range		0 to 10			0 to 10			0 to 10		V
Input Resistance	20	25	30	20	25	30	20	25	30	kΩ
Offset Voltage		±0.2	±0.5		±0.2	±0.5		±0.2	±0.5	mV
CHIP SELECT (CS)										
RMS On Level	Open or 2.4 V < V_C < + V_S			Open or 2.4 V < V_C < + V_S			Open or 2.4 V < V_C < + V_S			
RMS Off Level	V_C < 0.2 V		V_C < 0.2 V	V_C < 0.2 V		V_C < 0.2 V	V_C < 0.2 V		V_C < 0.2 V	
I_{OUT} of Chip Select										
CS Low			10			10			10	μA
CS High			0			0			0	μA
On Time Constant		10 + ((25 kΩ) × C_{AV})			10 + ((25 kΩ) × C_{AV})			10 + ((25 kΩ) × C_{AV})		μs
Off Time Constant		10 + ((25 kΩ) × C_{AV})			10 + ((25 kΩ) × C_{AV})			10 + ((25 kΩ) × C_{AV})		μs
POWER SUPPLY										
Operating Voltage Range	±3.0		±18	±3.0		±18	±3.0		±18	V
Quiescent Current		2.2	3		2.2	3		2.2	3	mA
Standby Current		350	450		350	450		350	450	μA

¹ Specifications shown in **bold** are tested on all production units at final electrical test. Results from those tests are used to calculate outgoing quality levels.

All minimum and maximum specifications are guaranteed, although only those shown in boldface are tested on all production units.

² Accuracy specified 0 V rms to 7 V rms dc with AD637 connected, as shown in Figure 5.

³ Nonlinearity is defined as the maximum deviation from the straight line connecting the readings at 10 mV and 2 V.

⁴ Error vs. crest factor is specified as additional error for 1 V rms.

⁵ Input voltages are expressed in volts rms. Percent is in % of reading.

⁶ With external 2 kΩ pull-down resistor tied to - V_S .

ABSOLUTE MAXIMUM RATINGS

Table 2.

Parameter	Rating
ESD Rating	500 V
Supply Voltage	± 18 V dc
Internal Quiescent Power Dissipation	108 mW
Output Short-Circuit Duration	Indefinite
Storage Temperature Range	-65°C to $+150^{\circ}\text{C}$
Lead Temperature (Soldering 10 sec)	300°C
Rated Operating Temperature Range	
AD637J, AD637K	0°C to 70°C
AD637A, AD637B	-40°C to $+85^{\circ}\text{C}$
AD637S, 5962-8963701CA	-55°C to $+125^{\circ}\text{C}$

Stresses above those listed under Absolute Maximum Ratings may cause permanent damage to the device. This is a stress rating only; functional operation of the device at these or any other conditions above those indicated in the operational section of this specification is not implied. Exposure to absolute maximum rating conditions for extended periods may affect device reliability.

ESD CAUTION



ESD (electrostatic discharge) sensitive device. Charged devices and circuit boards can discharge without detection. Although this product features patented or proprietary protection circuitry, damage may occur on devices subjected to high energy ESD. Therefore, proper ESD precautions should be taken to avoid performance degradation or loss of functionality.

AD637

PIN CONFIGURATIONS AND FUNCTION DESCRIPTIONS

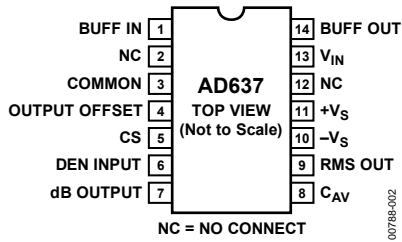

Figure 2. 14-Lead SBDIP/CERDIP Pin Configuration

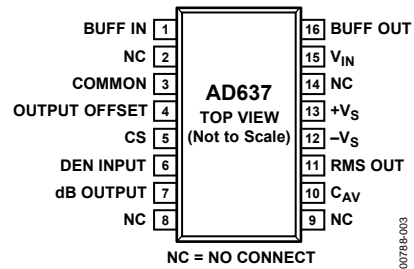

Figure 3. 16-Lead SOIC_W Pin Configuration

Table 3. 14-Lead SBDIP/CERDIP Pin Function Descriptions

Pin No.	Mnemonic	Description
1	BUFF IN	Buffer Input
2, 12	NC	No Connection
3	COMMON	Analog Common
4	OUTPUT OFFSET	Output Offset
5	CS	Chip Select
6	DEN INPUT	Denominator Input
7	dB OUTPUT	dB Output
8	C_{AV}	Averaging Capacitor Connection
9	RMS OUT	RMS Output
10	$-V_S$	Negative Supply Rail
11	$+V_S$	Positive Supply Rail
13	V_{IN}	Signal Input
14	BUFF OUT	Buffer Output

Table 4. 16-Lead SOIC_W Pin Function Descriptions

Pin No.	Mnemonic	Description
1	BUFF IN	Buffer Input
2, 8, 9, 14	NC	No Connection
3	COMMON	Analog Common
4	OUTPUT OFFSET	Output Offset
5	CS	Chip Select
6	DEN INPUT	Denominator Input
7	dB OUTPUT	dB Output
10	C_{AV}	Averaging Capacitor Connection
11	RMS OUT	RMS Output
12	$-V_S$	Negative Supply Rail
13	$+V_S$	Positive Supply Rail
15	V_{IN}	Signal Input
16	BUFF OUT	Buffer Output

FUNCTIONAL DESCRIPTION

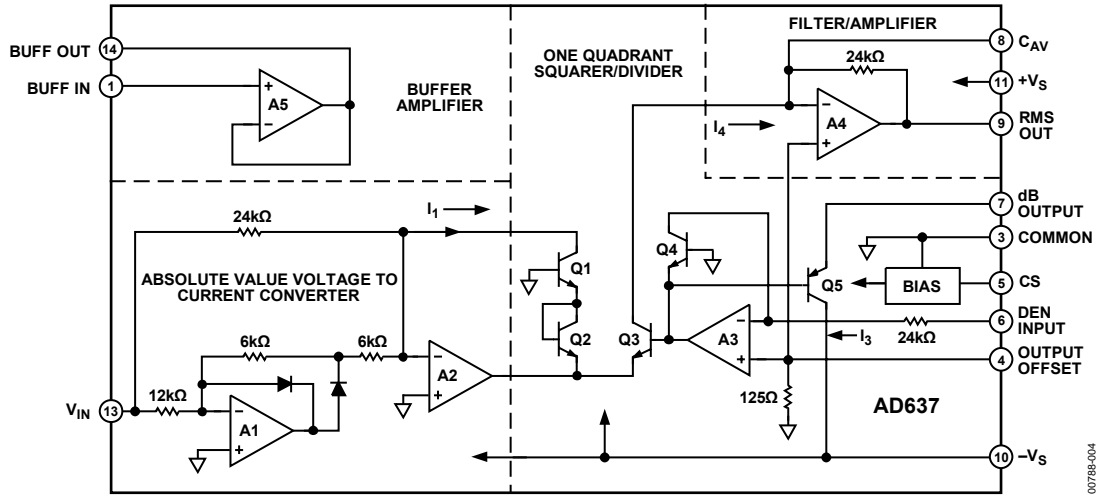

Figure 4. Simplified Schematic

00786-004

The AD637 embodies an implicit solution of the rms equation that overcomes the inherent limitations of straightforward rms computation. The actual computation performed by the AD637 follows the equation

$$V_{rms} = Avg \left[\frac{V_{IN}^2}{V_{rms}} \right]$$

Figure 4 is a simplified schematic of the AD637, subdivided into four major sections: absolute value circuit (active rectifier), squarer/divider, filter circuit, and buffer amplifier. The input voltage (V_{IN}), which can be ac or dc, is converted to a unipolar current I_1 by the active rectifiers A1 and A2. I_1 drives one input of the squarer/divider, which has the transfer function

$$I_4 = \frac{I_1^2}{I_3}$$

The output current of the squarer/divider I_4 drives A4, forming a low-pass filter with the external averaging capacitor. If the RC time constant of the filter is much greater than the longest period of the input signal, then the A4 output is proportional to the average of I_4 . The output of this filter amplifier is used by A3 to provide the denominator current I_3 , which equals $Avg I_4$ and is returned to the squarer/divider to complete the implicit rms computation

$$I_4 = Avg \left[\frac{I_1^2}{I_4} \right] = I_1 \text{ rms}$$

and

$$V_{OUT} = V_{IN} \text{ rms}$$

To compute the absolute value of the input signal, the averaging capacitor is omitted. However, a small capacitance value at the averaging capacitor pin is recommended to maintain stability; 5 pF is sufficient for this purpose. The circuit operates identically to that of the rms configuration, except that I_3 is now equal to I_4 , giving

$$I_4 = \frac{I_1^2}{I_4}$$

$$I_4 = |I_1|$$

The denominator current can also be supplied externally by providing a reference voltage (V_{REF}) to Pin 6. The circuit operates identically to the rms case, except that I_3 is now proportional to V_{REF} . Therefore,

$$I_4 = Avg \frac{I_1^2}{I_3}$$

and

$$V_{OUT} = \frac{V_{IN}^2}{V_{DEN}}$$

This is the mean square of the input signal.

AD637

STANDARD CONNECTION

The AD637 is simple to connect for a majority of rms measurements. In the standard rms connection shown in Figure 5, only a single external capacitor is required to set the averaging time constant. In this configuration, the AD637 computes the true rms of any input signal. An averaging error, the magnitude of which is dependent on the value of the averaging capacitor, is present at low frequencies. For example, if the filter capacitor, C_{AV} , is 4 μF , the error is 0.1% at 10 Hz and increases to 1% at 3 Hz. To measure ac signals, the AD637 can be ac-coupled by adding a nonpolar capacitor in series with the input, as shown in Figure 5.

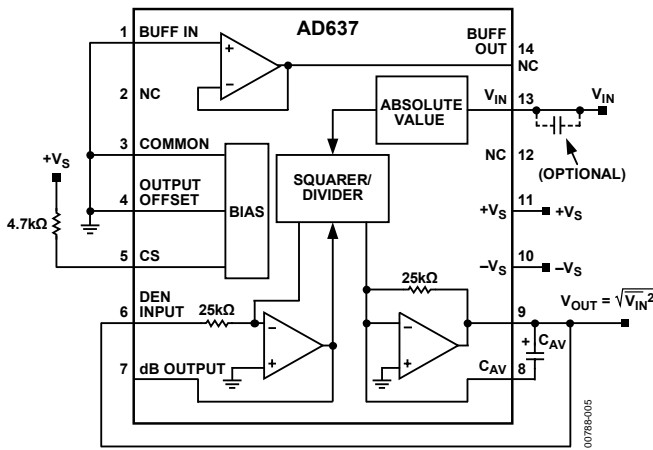

Figure 5. Standard RMS Connection

The performance of the AD637 is tolerant of minor variations in the power supply voltages; however, if the supplies used exhibit a considerable amount of high frequency ripple, it is advisable to bypass both supplies to ground through a 0.1 μF ceramic disc capacitor placed as close to the device as possible.

The output signal range of the AD637 is a function of the supply voltages, as shown in Figure 6. The output signal can be used buffered or nonbuffered, depending on the characteristics of the load. If no buffer is needed, tie the buffer input (Pin 1) to common. The output of the AD637 is capable of driving 5 mA into a 2 k Ω load without degrading the accuracy of the device.

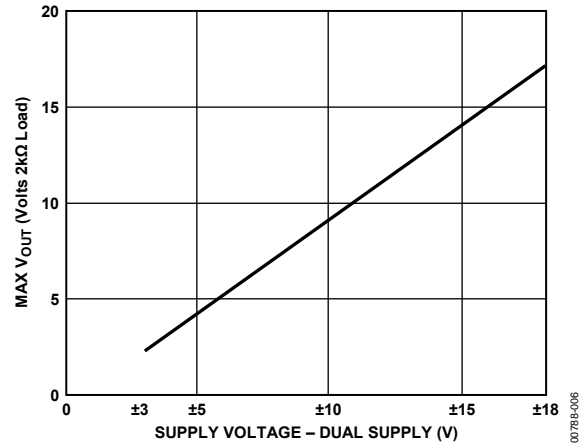

Figure 6. Maximum V_{OUT} vs. Supply Voltage

CHIP SELECT

The AD637 includes a chip select feature that allows the user to decrease the quiescent current of the device from 2.2 mA to 350 μA . This is done by driving CS, Pin 5, to below 0.2 V dc. Under these conditions, the output goes into a high impedance state. In addition to reducing the power consumption, the outputs of multiple devices can be connected in parallel to form a wide bandwidth rms multiplexer. Tie Pin 5 high to disable the chip select.

OPTIONAL TRIMS FOR HIGH ACCURACY

The AD637 includes provisions for trimming out output offset and scale factor errors resulting in significant reduction in the maximum total error, as shown in Figure 7. The residual error is due to a nontrimmable input offset in the absolute value circuit and the irreducible nonlinearity of the device.

Referring to Figure 8, the trimming process is as follows:

- Offset trim: Ground the input signal (V_{IN}) and adjust R1 to give 0 V output from Pin 9. Alternatively, R1 can be adjusted to give the correct output with the lowest expected value of V_{IN} .
- Scale factor trim: Resistor R4 is inserted in series with the input to lower the range of the scale factor. Connect the desired full-scale input to V_{IN} , using either a dc or a calibrated ac signal, and trim Resistor R3 to give the correct output at Pin 9 (that is, 1 V dc at the input results in a dc output voltage of 1.000 V dc). A 2 V p-p sine wave input yields 0.707 V dc at the output. Remaining errors are due to the nonlinearity.

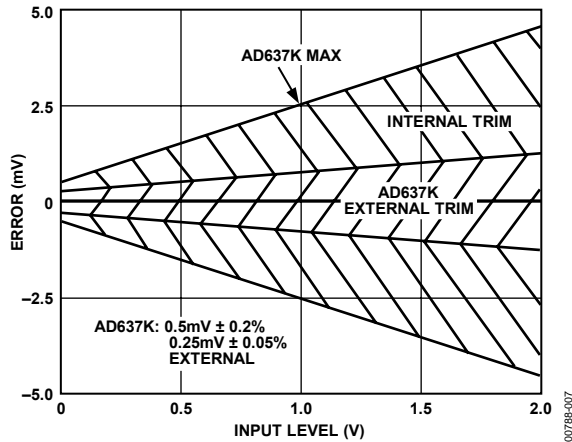

Figure 7. Maximum Total Error vs. Input Level AD637K Internal and External Trims

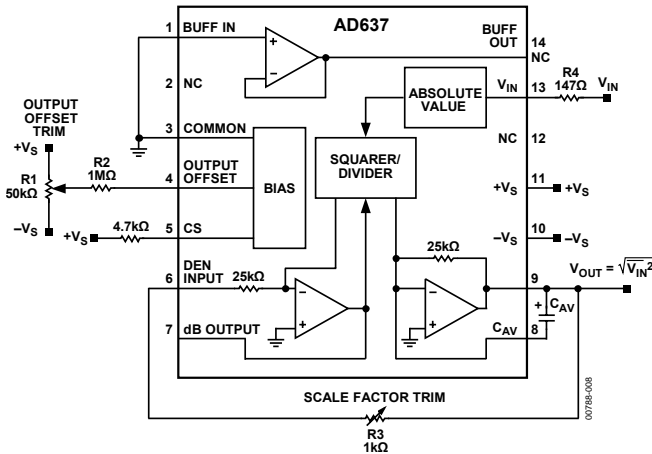

Figure 8. Optional External Gain and Offset Trims

CHOOSING THE AVERAGING TIME CONSTANT

The AD637 computes the true rms value of both dc and ac input signals. At dc, the output tracks the absolute value of the input exactly; with ac signals, the AD637 output approaches the true rms value of the input. The deviation from the ideal rms value is due to an averaging error. The averaging error comprises an ac component and a dc component. Both components are functions of input signal frequency f and the averaging time constant τ (τ : 25 ms/ μ F of averaging capacitance). Figure 9 shows that the averaging error is defined as the peak value of the ac component (ripple) and the value of the dc error.

The peak value of the ac ripple component of the averaging error is defined approximately by the relationship

$$\frac{50}{6.3 \tau f} \text{ in \% of reading where } (\tau > 1/f)$$

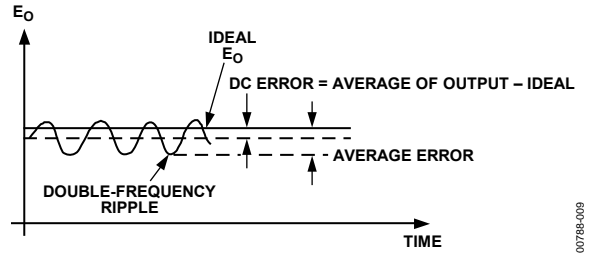

Figure 9. Typical Output Waveform for a Sinusoidal Input

This ripple can add a significant amount of uncertainty to the accuracy of the measurement being made. The uncertainty can be significantly reduced through the use of a postfiltering network or by increasing the value of the averaging capacitor.

The dc error appears as a frequency dependent offset at the output of the AD637 and follows the relationship

$$\frac{1}{0.16 + 6.4 \tau^2 f^2} \text{ in \% of reading}$$

Because the averaging time constant, set by C_{AV} , directly sets the time that the rms converter holds the input signal during computation, the magnitude of the dc error is determined only by C_{AV} and is not affected by postfiltering.

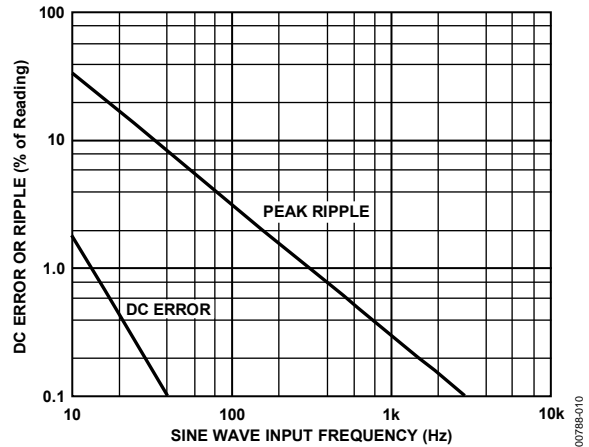

Figure 10. Comparison of Percent DC Error to the Percent Peak Ripple over Frequency Using the AD637 in the Standard RMS Connection with a $1 \times \mu\text{F } C_{AV}$

The ac ripple component of averaging error is greatly reduced by increasing the value of the averaging capacitor. There are two major disadvantages to this: the value of the averaging capacitor becomes extremely large and the settling time of the AD637 increases in direct proportion to the value of the averaging capacitor ($T_s = 115 \text{ ms}/\mu\text{F}$ of averaging capacitance). A preferable method of reducing the ripple is by using the postfilter network, as shown in Figure 11. This network can be used in either a 1-pole or 2-pole configuration. For most applications, the 1-pole filter gives the best overall compromise between ripple and settling time.

AD637

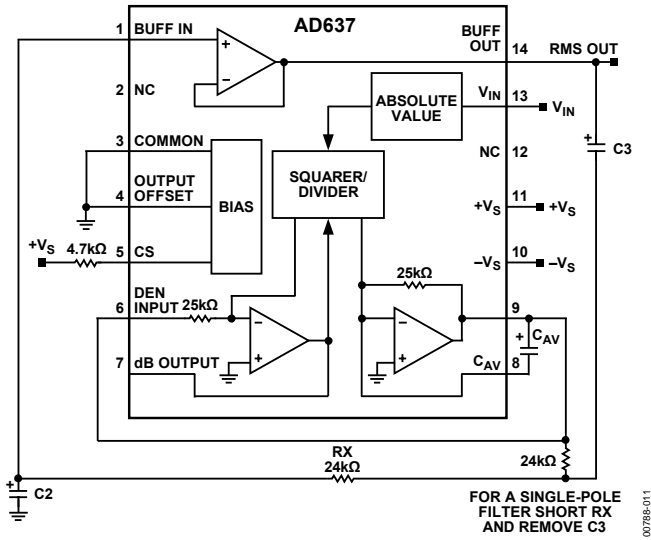

Figure 11. 2-Pole Sallen-Key Filter

Figure 12 shows values of C_{AV} and the corresponding averaging error as a function of sine wave frequency for the standard rms connection. The 1% settling time is shown on the right side of Figure 12.

Figure 13 shows the relationship between the averaging error, signal frequency settling time, and averaging capacitor value. Figure 13 is drawn for filter capacitor values of $3.3 \times$ the averaging capacitor value. This ratio sets the magnitude of the ac and dc errors equal at 50 Hz. As an example, by using a $1 \mu\text{F}$ averaging capacitor and a $3.3 \mu\text{F}$ filter capacitor, the ripple for a 60 Hz input signal is reduced from 5.3% of the reading using the averaging capacitor alone to 0.15% using the 1-pole filter. This gives a factor of 30 reduction in ripple, and yet the settling time only increases by a factor of 3. The values of filter Capacitor C_{AV} and Filter Capacitor C_2 can be calculated for the desired value of averaging error and settling time by using Figure 13.

The symmetry of the input signal also has an effect on the magnitude of the averaging error. Table 5 gives the practical component values for various types of 60 Hz input signals. These capacitor values can be directly scaled for frequencies other than 60 Hz—that is, for 30 Hz, these values are doubled, and for 120 Hz they are halved.

For applications that are extremely sensitive to ripple, the 2-pole configuration is suggested. This configuration minimizes capacitor values and the settling time while maximizing performance.

Figure 14 can be used to determine the required value of C_{AV} , C_2 , and C_3 for the desired level of ripple and settling time.

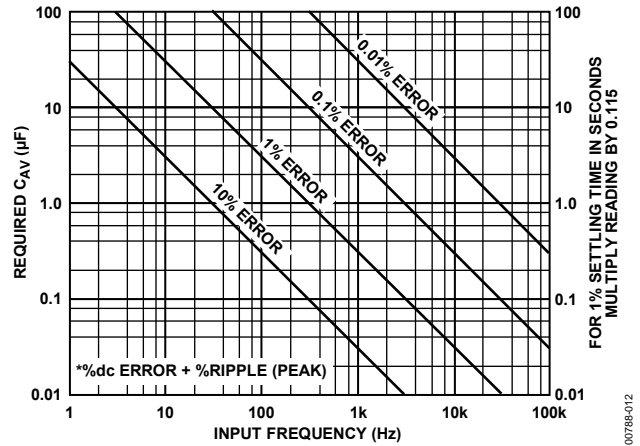

Figure 12. Values for C_{AV} and 1% Settling Time for Stated % of Reading Averaging Error* Accuracy Includes $\pm 2\%$ Component Tolerance (see * in Figure)

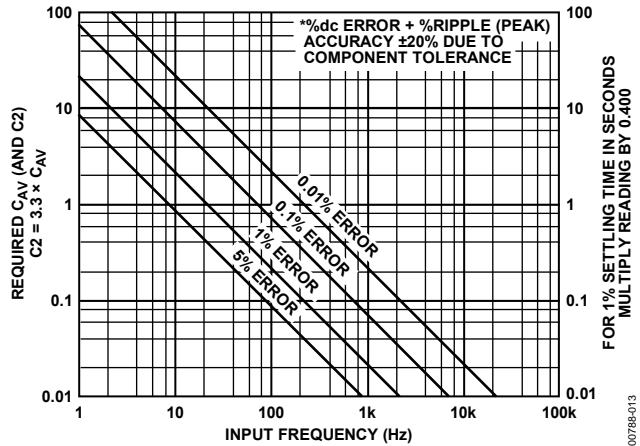

Figure 13. Values of C_{AV} , C_2 , and 1% Settling Time for Stated % of Reading Averaging Error* for 1-Pole Post Filter (see * in Figure)

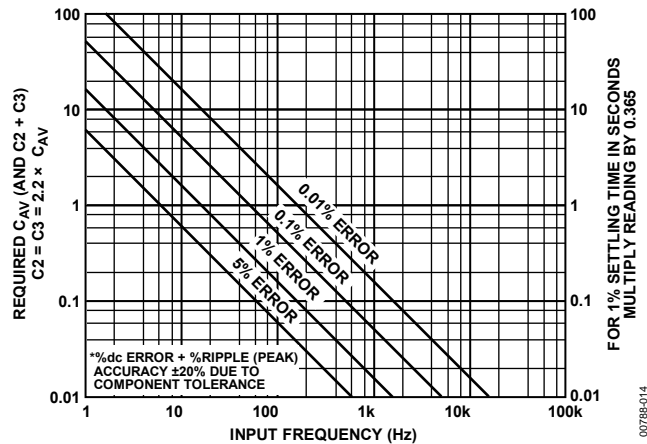
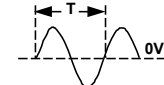
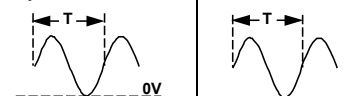
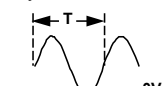
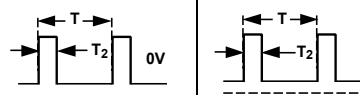
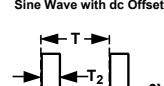
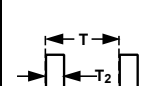
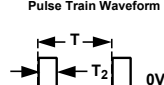
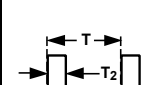

Figure 14. Values of C_{AV} , C_2 , and C_3 and 1% Settling Time for Stated % of Reading Averaging Error* for 2-Pole Sallen-Key Filter (see * in Figure)

Table 5. Practical Values of C_{AV} and C_2 for Various Input Waveforms

Input Waveform and Period	Absolute Value Circuit Waveform and Period	Minimum $R \times C_{AV}$ Time Constant	Recommended Standard Values for C_{AV} and C_2 for 1% Averaging Error @ 60 Hz with $T = 16.6$ ms		1% Settling Time
			C_{AV} (μF)	C_2 (μF)	
<p>A</p>  <p>Symmetrical Sine Wave</p>		$1/2T$	0.47	1.5	181 ms
<p>B</p>  <p>Sine Wave with dc Offset</p>		T	0.82	2.7	325 ms
<p>C</p>  <p>Pulse Train Waveform</p>		$10(T - T_2)$	6.8	22	2.67 sec
<p>D</p> 		$10(T - 2T_2)$	5.6	18	2.17 sec

FREQUENCY RESPONSE

The frequency response of the AD637 at various signal levels is shown in Figure 15. The dashed lines show the upper frequency limits for 1%, 10%, and ± 3 dB of additional error. For example, note that for 1% additional error with a 2 V rms input, the highest frequency allowable is 200 kHz. A 200 mV signal can be measured with 1% error at signal frequencies up to 100 kHz.

To take full advantage of the wide bandwidth of the AD637, care must be taken in the selection of the input buffer amplifier. To ensure that the input signal is accurately presented to the converter, the input buffer must have a -3 dB bandwidth that is wider than that of the AD637. Note the importance of slew rate in this application. For example, the minimum slew rate required for a 1 V rms, 5 MHz, sine wave input signal is 44 V/ μ s. The user is cautioned that this is the minimum rising or falling slew rate and that care must be exercised in the selection of the buffer amplifier, because some amplifiers exhibit a two-to-one difference between rising and falling slew rates. The AD845 is recommended as a precision input buffer.

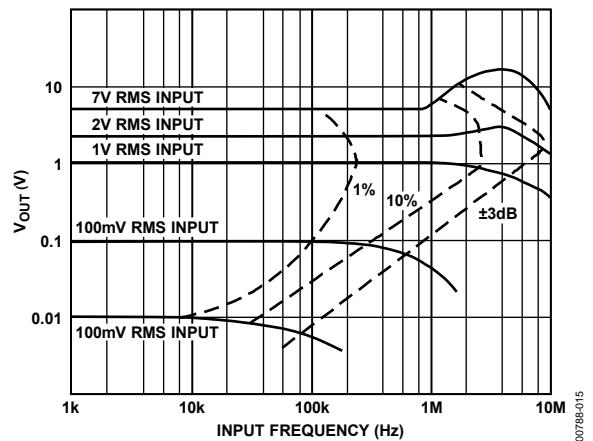

Figure 15. Frequency Response

AC MEASUREMENT ACCURACY AND CREST FACTOR

Crest factor is often overlooked in determining the accuracy of an ac measurement. Crest factor is defined as the ratio of the peak signal amplitude to the rms value of the signal ($CF = V_p/V_{rms}$). Most common waveforms, such as sine and triangle waves, have relatively low crest factors (≤ 2). Waveforms that resemble low duty cycle pulse trains, such as those occurring in switching power supplies and SCR circuits, have high crest factors. For example, a rectangular pulse train with a 1% duty cycle has a crest factor of 10 ($CF = 1/\sqrt{\eta}$).

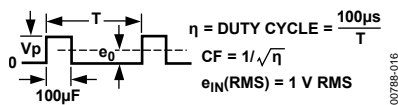

Figure 16. Duty Cycle Timing

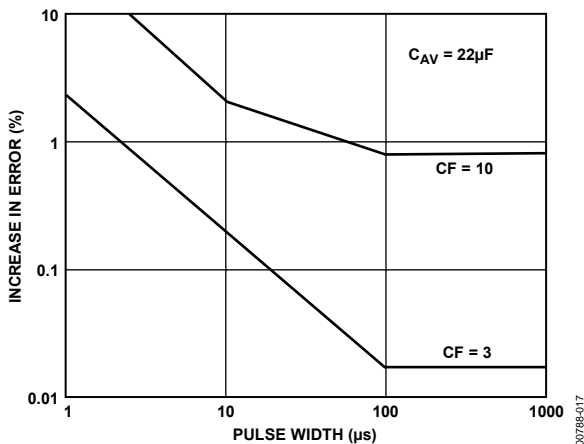

Figure 17. AD637 Error vs. Pulse Width Rectangular Pulse

Figure 18 is a curve of additional reading error for the AD637 for a 1 V rms input signal with crest factors from 1 to 11. A rectangular pulse train (pulse width $100 \mu s$) is used for this test because it is the worst-case waveform for rms measurement (all the energy is contained in the peaks). The duty cycle and peak amplitude were varied to produce crest factors from 1 to 10 while maintaining a constant 1 V rms input amplitude.

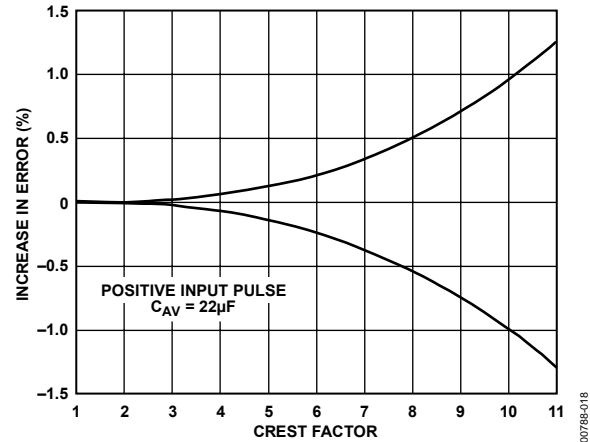

Figure 18. Additional Error vs. Crest Factor

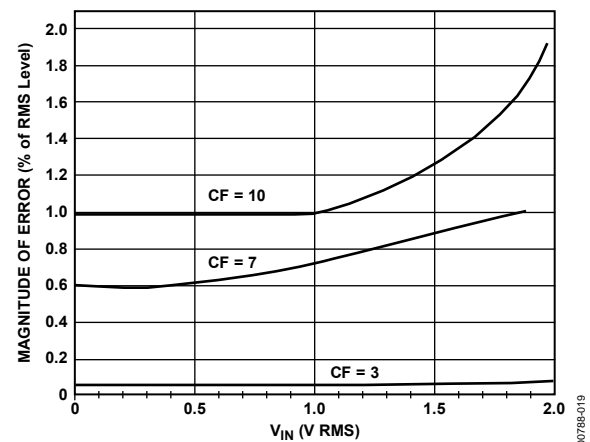

Figure 19. Error vs. RMS Input Level for Three Common Crest Factors

CONNECTION FOR dB OUTPUT

Another feature of the AD637 is the logarithmic, or decibel, output. The internal circuit that computes dB works well over a 60 dB range. Figure 20 shows the dB measurement connection. The user selects the 0 dB level by setting R_1 for the proper 0 dB reference current, which is set to cancel the log output current from the squarer/divider circuit at the desired 0 dB point. The external op amp is used to provide a more convenient scale and to allow compensation of the $+0.33\%/^{\circ}C$ temperature drift of the dB circuit. The temperature resistor R_3 , as shown in Figure 20, is available from Precision Resistor Co., Inc., in Largo, Fla. (Model PT146). Consult its website for additional information.

dB CALIBRATION

Refer to Figure 20:

- Set $V_{IN} = 1.00\text{ V dc or }1.00\text{ V rms}$
- Adjust R1 for $0\text{ dB out} = 0.00\text{ V}$
- Set $V_{IN} = 0.1\text{ V dc or }0.10\text{ V rms}$
- Adjust R2 for $\text{dB out} = -2.00\text{ V}$

Any other dB reference can be used by setting V_{IN} and R1 accordingly.

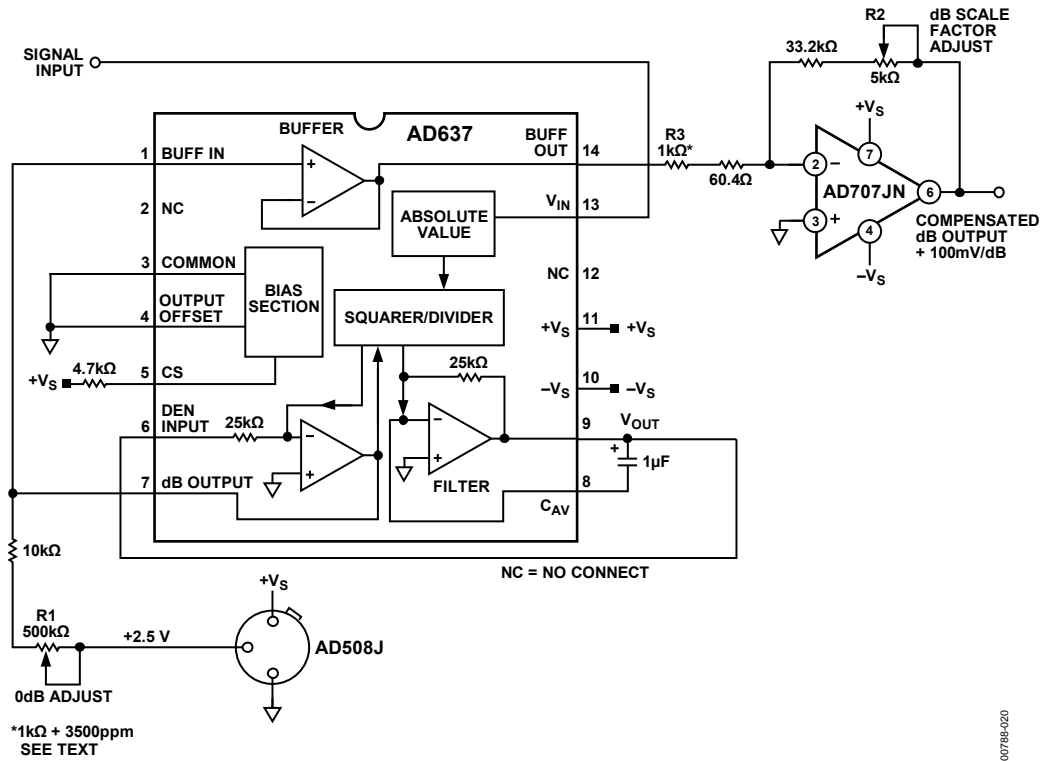
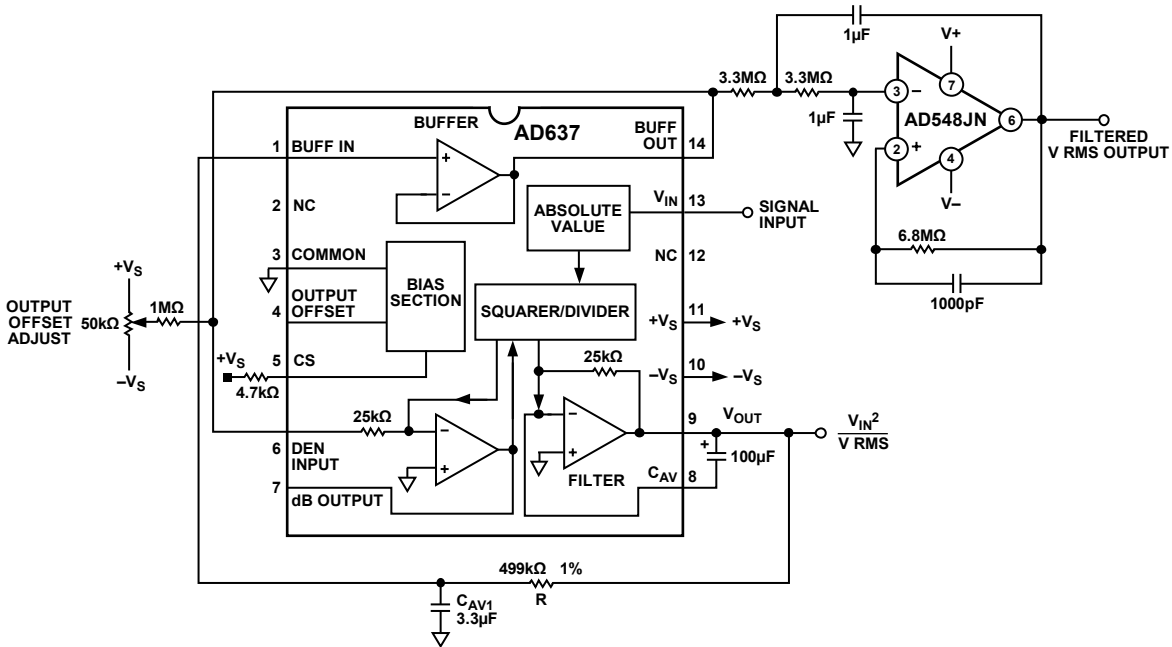

Figure 20. dB Connection



- NOTES**
 1. VALUES CHOSEN TO GIVE 0.1% AVERAGING ERROR @ 1Hz.
 2. NC = NO CONNECT.

Figure 21. AD637 as a Low Frequency RMS Converter

00789421

LOW FREQUENCY MEASUREMENTS

If the frequencies of the signals to be measured are below 10 Hz, the value of the averaging capacitor required to deliver even 1% averaging error in the standard rms connection becomes extremely large. Figure 21 shows an alternative method of obtaining low frequency rms measurements. The averaging time constant is determined by the product of R and C_{AV} , in this circuit, 0.5 sec/ μF of C_{AV} . This circuit permits a 20:1 reduction in the value of the averaging capacitor, permitting the use of high quality tantalum capacitors. It is suggested that the 2-pole, Sallen-Key filter shown in Figure 21 be used to obtain a low ripple level and minimize the value of the averaging capacitor.

If the frequency of interest is below 1 Hz, or if the value of the averaging capacitor is still too large, the 20:1 ratio can be increased. This is accomplished by increasing the value of R. If this is done, it is suggested that a low input current, low offset voltage amplifier, such as the AD548, be used instead of the internal buffer amplifier. This is necessary to minimize the offset error introduced by the combination of amplifier input currents and the larger resistance.

VECTOR SUMMATION

Vector summation can be accomplished through the use of two AD637s, as shown in Figure 22. Here, the averaging capacitors are omitted (nominal 100 pF capacitors are used to ensure stability of the filter amplifier), and the outputs are summed as shown. The output of the circuit is

$$V_{OUT} = \sqrt{V_X^2 + V_Y^2}$$

This concept can be expanded to include additional terms by feeding the signal from Pin 9 of each additional AD637 through a 10 k Ω resistor to the summing junction of the AD711 and tying all of the denominator inputs (Pin 6) together.

If C_{AV} is added to IC1 in this configuration, then the output is

$$\sqrt{V_X^2 + V_Y^2}$$

If the averaging capacitor is included on both IC1 and IC2, the output is

$$\sqrt{V_X^2 + V_Y^2}$$

This circuit has a dynamic range of 10 V to 10 mV and is limited only by the 0.5 mV offset voltage of the AD637. The useful bandwidth is 100 kHz.

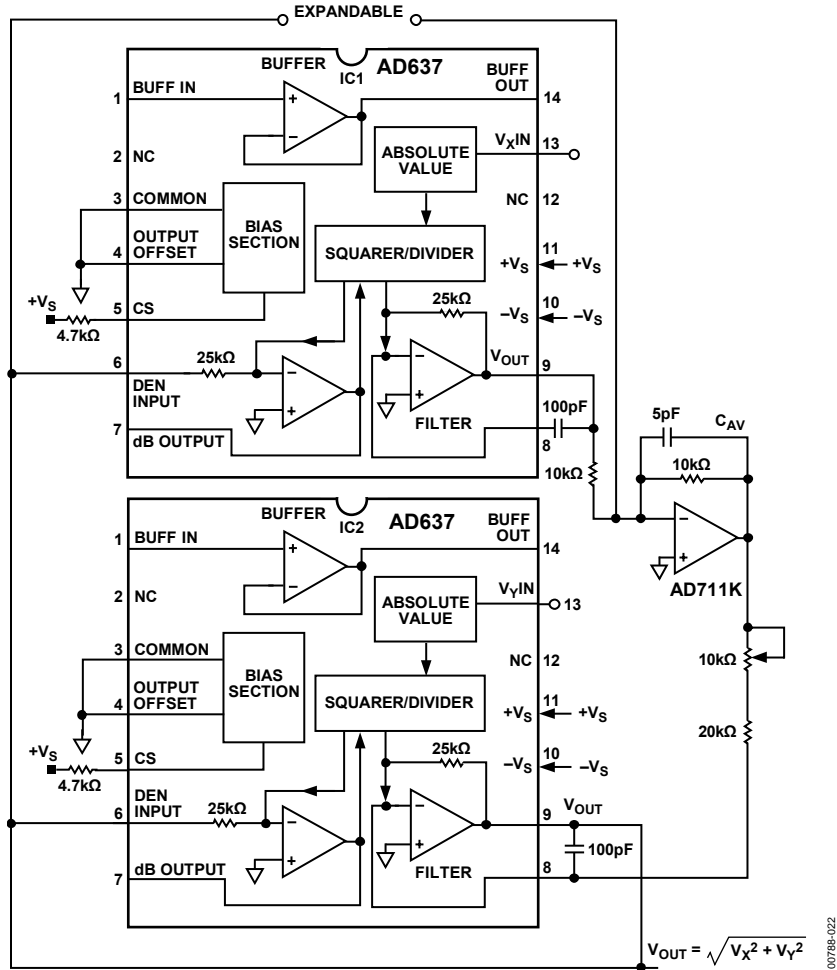

Figure 22. Vector Sum Configuration

EVALUATION BOARD

The evaluation board for the AD637 is shown in Figure 23. It is available at www.analog.com and ships fully tested and ready for bench testing by just adding power and signal connections. The circuit is configured for dual power supplies, and standard BNC connectors serve as the signal input and output ports.

Referring to the schematic in Figure 29, the input BNC RMS_IN is capacitively coupled to Pin 15 V_{IN} of the AD637. The BNC connector DC_OUT is connected to Pin 11, RMS OUT, with provisions for connections to the output buffer between Pin 1 and Pin 16. Users can connect the buffer using components of their choice. A trimmer is available for adjusting the output offset voltage. The board contains provisions for one or two poles of low-pass filtering using CF1, CF2, R4, and R5. See Figure 24 to locate these components.

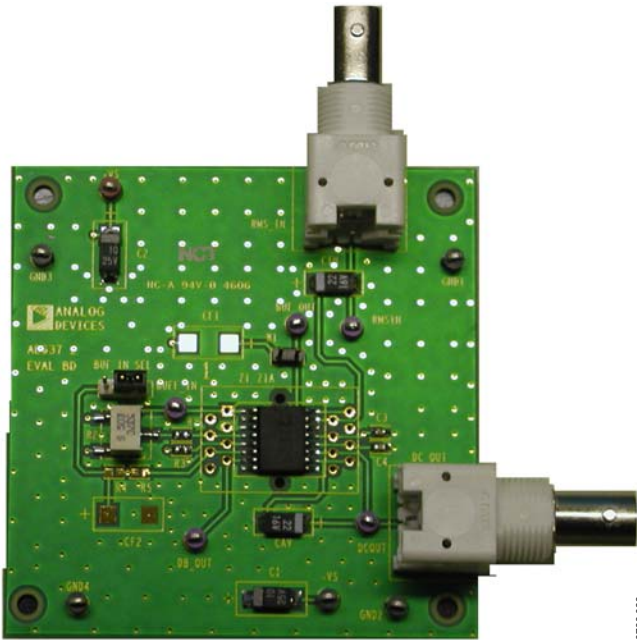

Figure 23. Evaluation Board

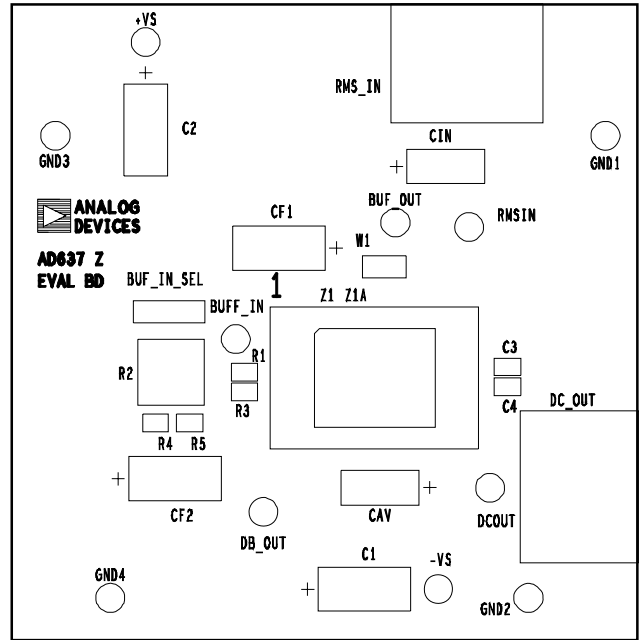

Figure 24. Evaluation Board—Component Side Silkscreen

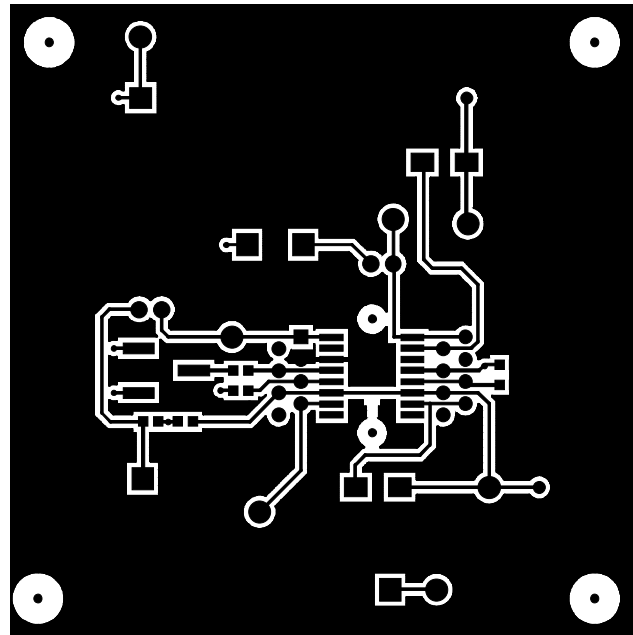
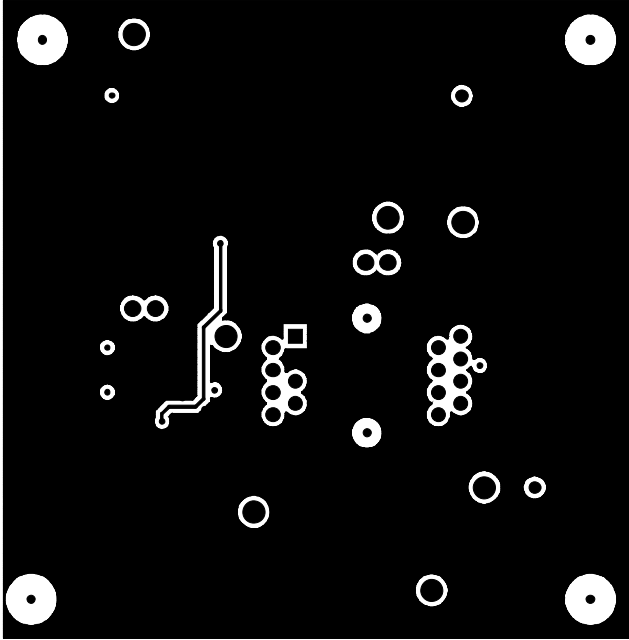
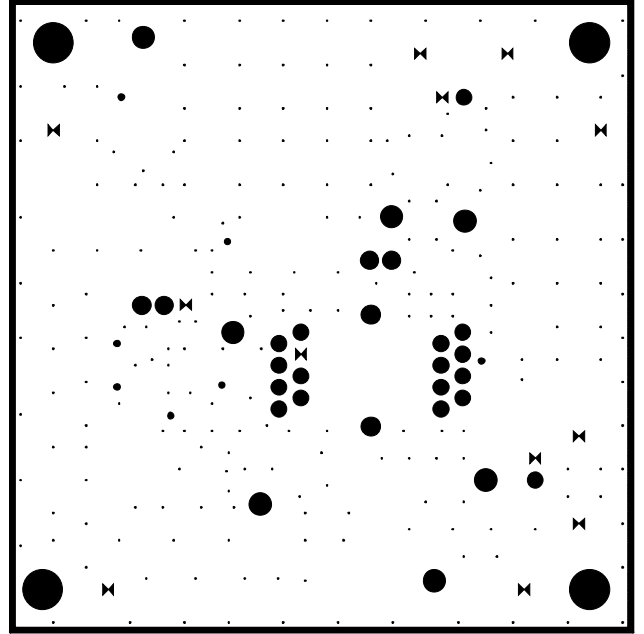

Figure 25. Evaluation Board—Component Side Copper



00788-026

Figure 26. Evaluation Board—Secondary Side Copper



00788-028

Figure 28. Evaluaiton Board—Internal Ground Plane

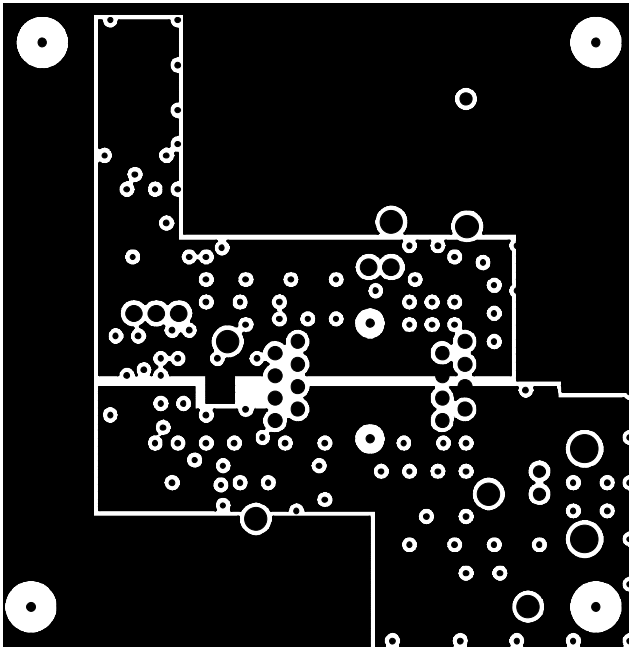

00788-027

Figure 27. Evaluation Board—Internal Power Plane

AD637

Table 6. Evaluation Board Bill of Materials

Qty	Name	Description	Reference Designator	Manufacturer	Mfg. Part Number
1	Test Loop	Red	+VS	Components Corp.	TP-104-01-02
1	Test Loop	Green	-VS	Components Corp.	TP-104-01-05
5	Test Loop	Purple	BUF IN, BUF OUT, RMS IN, DC OUT, DB OUT	Components Corp.	TP-104-01-07
1	Header	3-pin	BUF IN SEL	Molex	22-10-2031
2	Capacitor	Tantalum 10 μ F, 25 V	C1, C2	Nichicon	F931E106MCC
2	Capacitor	0.1 μ F, 16 V, 0603 X7R	C3, C4	Kemet	C0603C104K4RACTU
1	Capacitor	Tantalum 22 μ F, 16 V	CIN	Nichicon	F931C226MCC
2	Connector	BNC right angle	RMS IN, DC OUT	AMP	227161-1
4	Test Loop	Black	GND1, GND2, GND3, GND4	Components Corp.	TP-104-01-00
1	Resistor	1 M Ω , 5%, 1/10W, 0603	R1	Panasonic	ERJ-3EKF1004V
1	Trimmer	50 k Ω , 6 mm sq SMD	R2	Bourns	3361S-1-503G
1	Resistor	4.75k Ω , 5%, 1/10W, 0603	R3	Panasonic	ERJ-3EKF4751V
1	Header	BERG 2	W1	Molex	22-10-2021
1	Integrated Circuit	RMS-to-dc converter	Z1	Analog Devices, Inc.	AD637ARZ

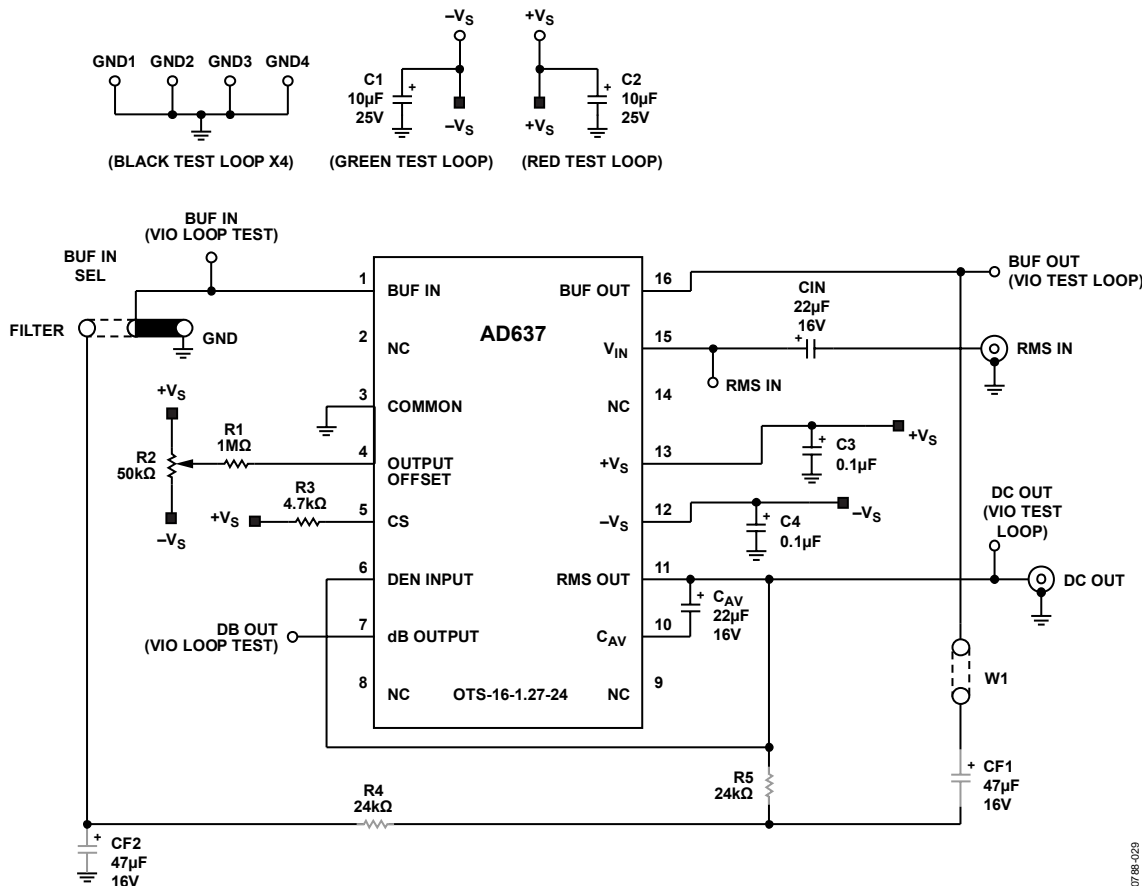
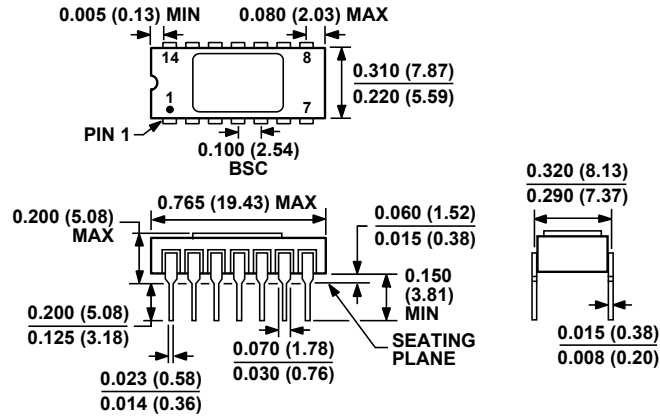

Figure 29. Evaluation Board Schematic

00788-029

OUTLINE DIMENSIONS



CONTROLLING DIMENSIONS ARE IN INCHES; MILLIMETER DIMENSIONS (IN PARENTHESES) ARE ROUNDED-OFF INCH EQUIVALENTS FOR REFERENCE ONLY AND ARE NOT APPROPRIATE FOR USE IN DESIGN.

Figure 30. 14-Lead Side-Braced Ceramic Dual In-Line Package [SBDIP] (D-14)

Dimensions shown in inches and (millimeters)

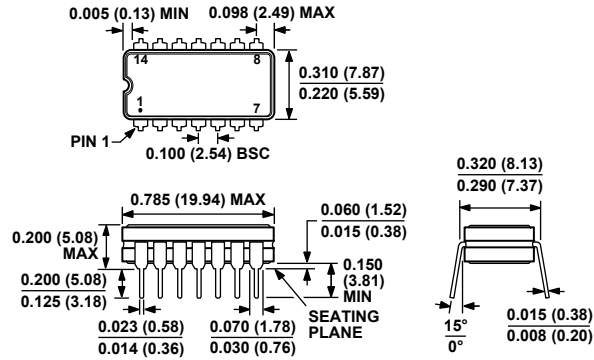

CONTROLLING DIMENSIONS ARE IN INCHES; MILLIMETER DIMENSIONS (IN PARENTHESES) ARE ROUNDED-OFF INCH EQUIVALENTS FOR REFERENCE ONLY AND ARE NOT APPROPRIATE FOR USE IN DESIGN.

Figure 31. 14-Lead Ceramic Dual In-Line Package [CERDIP] (Q-14)

Dimensions shown in inches and (millimeters)

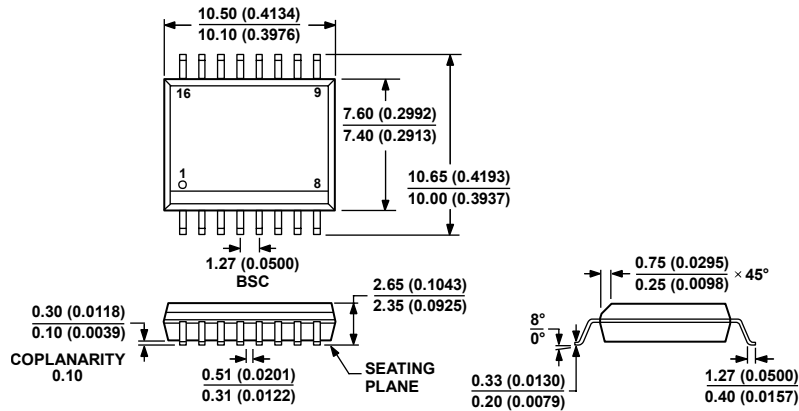

COMPLIANT TO JEDEC STANDARDS MS-013-AA
CONTROLLING DIMENSIONS ARE IN MILLIMETERS; INCH DIMENSIONS
(IN PARENTHESES) ARE ROUNDED-OFF MILLIMETER EQUIVALENTS FOR
REFERENCE ONLY AND ARE NOT APPROPRIATE FOR USE IN DESIGN.

Figure 32. 16-Lead Standard Small Outline Package [SOIC_W]
Wide Body (RW-16)
Dimensions shown in millimeters and (inches)

032707-B

ORDERING GUIDE

Model	Temperature Range	Package Description	Package Option
5962-8963701CA ¹	-55°C to +125°C	14-Lead CERDIP	Q-14
AD637AQ	-40°C to +85°C	14-Lead CERDIP	Q-14
AD637AR	-40°C to +85°C	16-Lead SOIC_W	RW-16
AD637ARZ ²	-40°C to +85°C	16-Lead SOIC_W	RW-16
AD637BQ	-40°C to +85°C	14-Lead CERDIP	Q-14
AD637BR	-40°C to +85°C	16-Lead SOIC_W	RW-16
AD637BRZ	-40°C to +85°C	16-Lead SOIC_W	RW-16
AD637JD	0°C to 70°C	14-Lead SBDIP	D-14
AD637JDZ	0°C to 70°C	14-Lead SBDIP	D-14
AD637JQ	0°C to 70°C	14-Lead CERDIP	Q-14
AD637JR	0°C to 70°C	16-Lead SOIC_W	RW-16
AD637JR-REEL	0°C to 70°C	16-Lead SOIC_W	RW-16
AD637JR-REEL7	0°C to 70°C	16-Lead SOIC_W	RW-16
AD637JRZ	0°C to 70°C	16-Lead SOIC_W	RW-16
AD637JRZ-RL	0°C to 70°C	16-Lead SOIC_W	RW-16
AD637JRZ-R7	0°C to 70°C	16-Lead SOIC_W	RW-16
AD637KD	0°C to 70°C	14-Lead SBDIP	D-14
AD637KDZ	0°C to 70°C	14-Lead SBDIP	D-14
AD637KQ	0°C to 70°C	14-Lead CERDIP	Q-14
AD637KR	0°C to 70°C	16-Lead SOIC_W	RW-16
AD637KRZ	0°C to 70°C	16-Lead SOIC_W	RW-16
AD637SD	-55°C to +125°C	14-Lead SBDIP	D-14
AD637SD/883B	-55°C to +125°C	14-Lead SBDIP	D-14
AD637SQ/883B	-55°C to +125°C	14-Lead CERDIP	Q-14
AD637-EVALZ		Evaluation Board	

¹ A standard microcircuit drawing is available.

² Z = RoHS Compliant Part.